

• Dumpers hidrostáticos

• *Hydrostatic dumpers* • Dumpers hydrostatiques

Modelos • *Models* • Modèles

- DH - 200 H
- DH - 250 H
- DH - 200 PH
- DH - 250 PH



	H 3	H4	L3	Vía delantera / L6 / Vía trasera	
DH - 200 H	1.200	240	2.990	1.290	1.340
DH - 250 H	1.340	315	1.300	1.300	1.340

Dimensiones • *Dimensions* • Dimensions

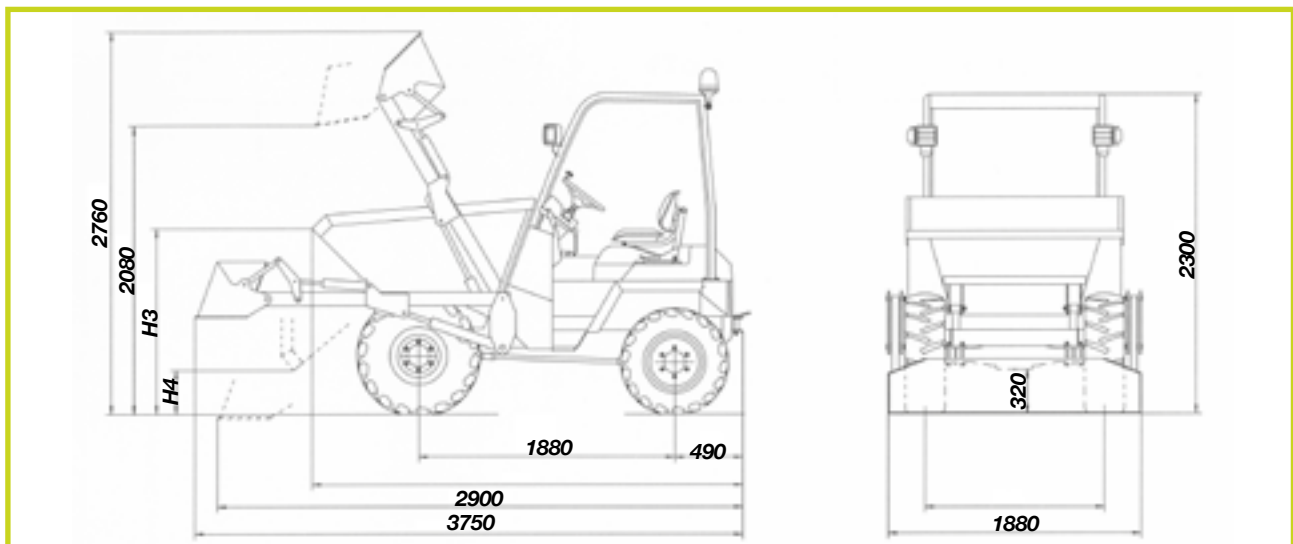

• DH - 200 / 250 H • DUMPERS

Características Técnicas • Technical Features • Caracteristiques Techniques

	CARGA ÚTIL	2.000 Kgs	2.500 Kgs
	NIVEL AGUA	835 L	980 L
	COLMADA	1,2 m ³	1,35 m ³
	PENDIENTE MAX.	42%	42%
	MOTOR	Diesel Perkins 3 Cilindros. 24,4 KW • 33,2 CV • 1496 cc. • Refrigerado por agua	Diesel Perkins 3 Cilindros. 24,4 KW • 33,2 CV • 1496 cc. • Refrigerado por agua
	TRANSMISIÓN	Hidrostática REXROTH .	Hidrostática REXROTH.
	VELOCIDADES	Lenta: 0 - 9 Km/h • Rápida: 0 - 20 Km/h	Lenta: 0 - 9 Km/h • Rápida: 0 - 20 Km/h
	DIRECCIÓN	Hidráulica sobre puente trasero	Hidráulica sobre puente trasero
	NEUMÁTICOS	Delanteras: 10,0/75-15,3 / Traseras: 8,0 / 75 -15,3	Delanteras: 11,5 / 80-15,3 / Traseras: 10,0 / 75 -15,3
	FRENOS	De servicio: Sobre eje delantero De estacionamiento: Sobre eje delantero	De servicio: Sobre eje delantero De estacionamiento: Sobre eje delantero
	PESO	200 H: 1.650 200 PH: 1.920	250 H: 1.785 250 PH: 2.055

	USEFUL LOAD	2.000 Kgs	2.500 Kgs
	WATER LEVEL	835 L	980 L
	FULL TO THE BRIM	1,2 m ³	1,35 m ³
	MAX. GRADABILITY	42%	42%
	ENGINE	Perkins Diesel 3 Cylinders. 24,4 KW / 32,7 HP / 1496 cc. • Water cooled	Perkins Diesel 3 Cylinders. • 24,4 KW / 32,7 HP / 1496 cc. • Water cooled
	TRANSMISSION	Hydrostatic REXROTH.	Hydrostatic REXROTH.
	SPEEDS	Slow: 0 - 9 Km/h • High: 0 - 20 Km/h	Slow: 0 - 9 Km/h • High: 0 - 20 Km/h
	STEERING	Hydraulic on the rear axle	Hydraulic on the rear axle
	WHEELS	Front: 10,0/75-15,3 • Rear: 8,0 / 75 -15,3	Front: 11,5 / 80-15,3 • Rear: 10,0 / 75 -15,3
	BRAKES	Service brake on rear axle parking brake on the rear axle	Service brake on rear axle parking brake on the rear axle
	WEIGHT	200 H: 1.650 200 PH: 1.920	250 H: 1.785 250 PH: 2.055

	CHARGE UTILE	2.000 Kgs	2.500 Kgs
	NIVEAU DE EAU	835 L	980 L
	PLEIN	1,2 m ³	1,35 m ³
	DECLIVITE MAX	42%	42%
	MOTEUR	Diesel Perkins 3 Cylindres. 24,4 KW • 33,2 CV • 1496 cc. • Par eau	Diesel Perkins 3 Cylindres. 24,4 KW • 33,2 CV • 1496 cc. • Par eau
	TRANSMISSION	Hydrostatique REXROTH.	Hydrostatique REXROTH.
	VITESSES	Lente: 0 - 9 Km/h • Rapide: 0 - 20 Km/h	Lente: 0 - 9 Km/h • Rapide: 0 - 20 Km/h
	DIRECTION	Direction hydraulique pont arriere	Direction hydraulique pont arriere
	ROUES	Avant: 1,0/75-15,3 • Arriere: 8,0 / 75 -15,3	Avant: 11,5 / 80-15,3 • Arriere: 10,0 / 75 -15,3
	FREINS	De service: pont arriere • Stationnement:pont	De service: pont arriere • Stationnement:pont
	POIDS	arriere 200 H: 1.650 200 PH: 1.920	arriere 250 H: 1.785 250 PH: 2.055