



LIFTS YOUR BUSINESS UP



TELESCOPIC HANDLERS

AGRICULTURE LINE



Working for long and well? With us you can.



Maximum performance and continuous operation. Letting you work for a long time and well. This is our mission.

Telescopic handlers for agriculture are material handling machines able to assure and increase farms productivity. Power, comfort and technology but also maximum customization are the key aspects of Faresin Industries telescopic range.

A range offering models with boom length **from 6 to 11 meters** with lifting capacity **from 2.6 to 7 tons**, able to offer **the right solution for any kind of job.**

New continuous transmission **VPS and VPSe** - born through the cooperation with Bosch Rexroth - which improves the use and the performance of our telescopic handlers both in precise and in heavy duty work. An industrial approach that allows to set up each model in a variety of configurations that differ in performance and optionals.

The innovations of our telescopic range make these machines even more **comfortable** and **efficient**, **suitable to work in every condition.**

These are some of the reasons that make us the best choice for the future of your business.

- Reduced consumption
- Optimal manoeuvrability
- Reduced work time cycles
- Multiple applications



Lifting heights
from 6 to 11 meters,
maximum lifting
capacity from 2.6
to 7 tons

Suppliers for high standards

We deal with the best suppliers on the market to guarantee compliance with the high quality standards of Faresin telescopic handlers and mixer wagons.

We choose quality suppliers to assure high quality standards.





The Range



SMALL RANGE 6.26

page 16

CONFIGURATIONS: CLASSIC 52

Maximum lifting capacity 2.6 t

Maximum height up to 6 mt

The **6.26** telescopic handler of the **Small Range** is the most suitable model for situations where facilities and work environments have limited space. With its 1.93 mt height and 2 m width, it provides performance even in narrow spaces without compromise and without giving up on performance. The 51,7 kW 4F Yanmar engine provides all required power for the handling operations.



COMPACT RANGE 7.30C / 9.30C

page 18

CONFIGURATIONS: CLASSIC 55 / CLASSIC 74 / HLS 55 / HLS 74 / VPS 100

Maximum lifting capacity 3 t

Maximum height from 7 mt to 9 mt

The **Compact range** - thanks to its reduced size - allows you to work in small spaces with extreme ease and to reach heights from 7 to 9 metres with a maximum capacity of 3000 kg.



MIDDLE RANGE 7.30E / 7.35 / 7.45 / 8.40 / 9.30 / 11.35

page 20

CONFIGURATIONS: CLASSIC 55 / CLASSIC 74 / HLS 74 / VPSe 100

Maximum lifting capacity from 3 t to 4.5 t

Maximum height from 7 mt to 11 mt

The **Middle Range** has 24 configurations suitable for agricultural companies seeking an adaptable machine that ensures management savings and high performances thanks to the new technologies applied. The multi-function range with solutions suitable for every use in agriculture.



HEAVY DUTY 9.60 / 9.70 / 10.65

page 22

CONFIGURATIONS: CLASSIC 74 / HLS 74 / VPSe 100

Maximum lifting capacity from 6 t to 7 t

Maximum height from 9 mt to 10 mt

The three new models of the **Heavy Duty** range offer power, precision and control. Available with different types of transmission, maximum speed of 40 km/h and 4 driving modes in HLS 74 and VPSe 100 configurations. Great capacity to handle material without giving up on standard machine performance. Especially required for Biogas plants for its great performances.

Cabin comfort, visibility and ergonomics

In this way working becomes easy and productive.

Queen Cab Cabin designed to favour **maximum comfort, efficiency and visibility**: everything under control.

Equipped with anatomical seat with adjustable armrests and adjustable steering wheel based on the driver's height.

Everything under control.

The cabin ensures maximum manoeuvrability of the telescopic handler thanks to a new control dashboard with **intuitive multifunctions LCD colour display**. The new **joystick ensures millimetric control of the boom and allows to control the machines direction**. On request, it is also possible to complete the setup with a Bluetooth interface radio and pneumatic suspension seat.

- Joystick with wrist rest
- Adjustable steering wheel and seat
- Ergonomic seat
- Color Multifunctional LCD Display

Queen Cab: more comfort, maximum visibility and precise manoeuvrability for better performance

With the Multi-function Joystick everything under control in every moment



Standard multi-functions hydraulic electro proportional joystick only in HLS, VPS, VPSe versions.



360° view, always.

The **Queen Cab** enables maximum visibility thanks to its **anti-glare glass surface expanded by 20%**.

A great view of the whole work area is assured by the large glass surfaces and an uninterrupted and elongated windshield at the front. The mirror on the right side of the machine enables you to keep under control even the hardly visible corners at the back.

Always pleasing conditions.

The **air conditioning, heating and ventilation** system allows you to work comfortably **365 days a year**.

On hot or cold days the operator will be able to easily adjust the temperature conditions inside the cabin according to his needs.

Easy and fast maintenance.

Cabin designed to make the maintenance of our telescopic handlers easy: the floor of the **Queen Cab** can be easily removed and cleaned.

- 360° view
- Standard front and rear LED work lights with high lighting capacity
- Document pockets
- Bottle holder
- Cabin compliant with standards ROPS, FOPS and ANSI



2

Standard Joystick for CLASSIC versions.

Engine

Power and reliability.

The **Deutz common rail TIER4F/ STAGE IV** 4 cylinder engines assures excellent power combined with low fuel consumption during every loading and handling operations.

The **longitudinal arrangement** of the engine enables optimal accessibility in case of support and inspections and gives the machine great operational stability.

The **air filter** is equipped with a dust ejecting system and a cyclonic pre-filter to significantly increase the time between maintenance.

Post-treatment of the exhaust gas.

Last generation Stage IV engines from 55kW with DOC and from 75 kW to 100 kW with DOC+SCR, different engine sizes optimized for every request.

- Consumption reduced by 20%
- Optimal accessibility for support and inspections
- TIER 4F / STAGE IV engines

Clean and efficient.

The **reversible fan** (optional) maintains the intake surfaces always clean by switching the airflow that crosses the heat exchanger, guaranteeing engine efficiency.





New bonnet designed to facilitate air outflow



Wide radiating surface to increase engine performance



Layout designed for easy maintenance of the radiator and the engine

Transmission: more reliability, more productivity.

VPS continuous variation transmission for the Compact range.

VPS (Variable Power System) continuous variation transmission for the Compact range which enables to reach a maximum speed of 40 km/h with no mechanical gearbox. This transmission provides you enhanced performance and **driving comfort**, coupled with a **thrust strength** perfectly dosed to operate in small spaces.

VPS. 3 driving modes:

- **Drive:** maximum speed up to 40km/h
- **Handling:** for handling operations where sensitivity is required but at the same time a high pushing force.
- **Creeper:** to use accessories such as sweepers and snow turbines



The most sophisticated continuous variation Transmission VPSe.

Designed in collaboration with Bosch Rexroth, **VPSe** is a continuous variation transmission with two hydrostatic motors coupled with an automatic double ratio gearbox.

The entire transmission system is managed by an electronic control unit giving the operator **the maximum performance in every work condition.**

The excellent driving performance makes this transmission convincing, allowing **sensitive and extremely precise driving at every speed.**

For an even more dynamic driving and greater thrust capacity while using high capacity buckets.



Full control in every work condition (VPSe).

- 1 - 3** Manual accelerator (1) to adjust independently the engine rpm of forward speed,(3) forward speed adjustment(**Creeper** mode).
- 2** Torque limiter to modulate the drive torque on the wheels (**Creeper** and **Handling** mode).

The 4 driving modes of the VPSe



Drive maximum transmission performance up to 40 km/h



Eco lower consumption during transfers up to 40 km/h



Handling to use the maximum thrust capacity available



Creeper for using accessories such as sweepers and snow turbines

Single Hydrostatic transmission.

Single gear transmission that allows speeding from 0 to 30 km/h; for handling materials easily in the working areas.

Hydrostatic Transmission with mechanical gearbox.

2 mechanical gears allows to reach 40 km/h and provides a variety of speed ranges for all types of work.

Specific transmission for Heavy Duty range.

This hydrostatic transmission with mechanical gearbox and 4 driving modes is suitable in every operating condition: from driving on the road at a maximum speed of 40 km/h to using large sized buckets.

Full control.

The **Inching** function integrated in the brake pedal is standard for the entire range, providing full control even for the more delicate handling operations.



4 steering wheels for maximum manoeuvrability and a reduced steering radius



4-driving wheel + 3 steering systems

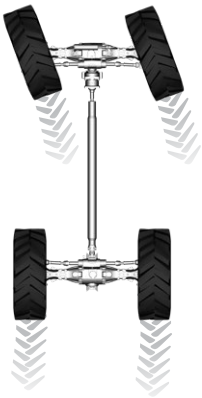

2 front steered wheels to guarantee road safety

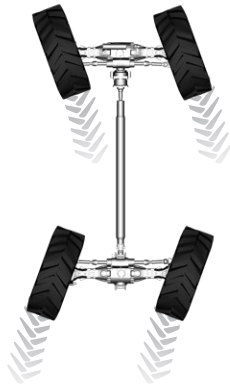

4 steering wheels to manoeuvre in sites with limited space

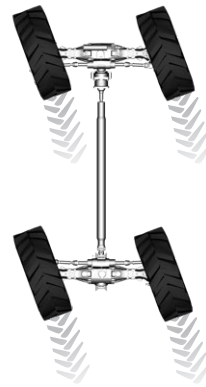

Crab steering for side approaches and delicate manoeuvres



Intelligent hydraulics.

High performance guaranteed. The advanced technology of intelligent hydraulics.

The *Compact*, *Middle* and *Heavy Duty* ranges in the versions with LS system implement the new regenerative system technology.

This technology recovers the oil leaving the non-supplied chamber of the boom-lifting cylinder to increase the capacity and therefore angular velocity. It substantially **reduces fuel consumption** and **cycle times** up to 60% compared to the machines without this technology.

Ecofast valve, Faresin exclusive.

The **EcoFast** recycling valve allows the boom to work at high speed with the Diesel engine at minimum rpm, saving fuel and reducing work cycle times (standard in Compact and Middle range supplied with LS pump).

Safety first.

With the **Slow Motion** function, the Ecofast valve slows down the boom putting the anti-rollover system in pre-alarm and with the **BLC (Bumpless Control)** function, it guarantees absorption of the shock resulting from the sudden stop of the boom.

The **Boom Speed Control** (optional) function enhances sensitivity and precision depending on the different types of jobs thanks to the adjustment of boom movements by using the potentiometer installed in the cabin.

The **Boom Suspension** (optional) function increases the comfort and the safety during the transfers on road with loads.

Manoeuvre and safety precision, anywhere.

The side levelling proportional control function ensures the maximum lifting capacity and safety on all types of ground. Standard for the **Heavy Duty** Range.

Variable flow rate pump
with load sensing distributor
to increase hydraulic capacity
and reduce cycle times



Chassis and boom extraordinary sturdiness.

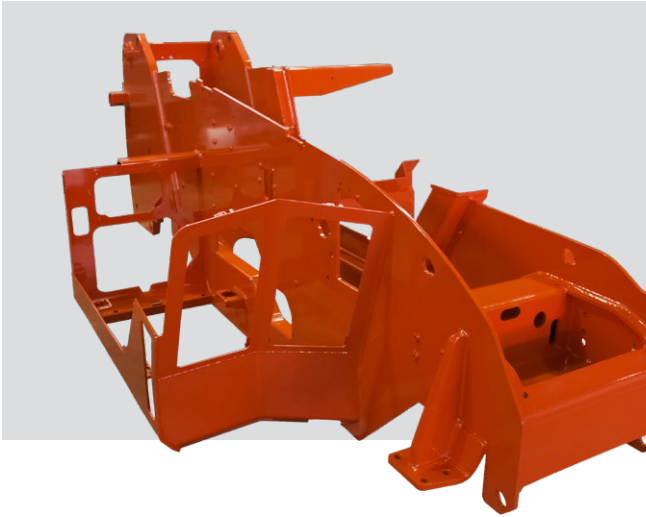

Sturdy chassis and boom made of special steel welded by robotic systems

The new single block chassis configuration of Faresin telescopic handlers ensures a low centre of gravity in order to offer more stability. Its **modular structure** provides particularly high **torsion resistance** and **optimal stability in all conditions**.

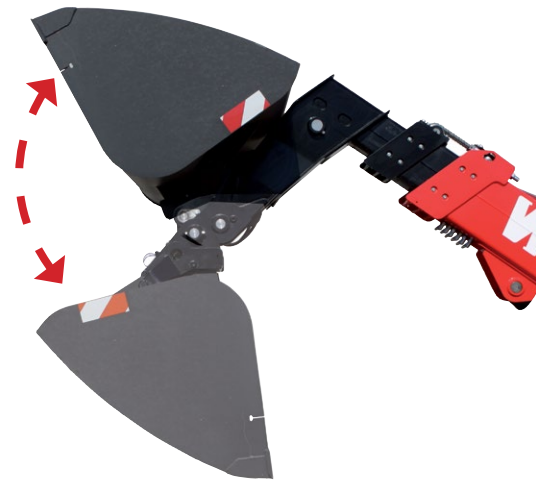

- Sturdy chassis made in S355 special steel
- Fully welded by Robotic systems to ensure the highest quality
- Durability even during the most extreme work conditions

155° tilting for small and compact range: the highest of its category



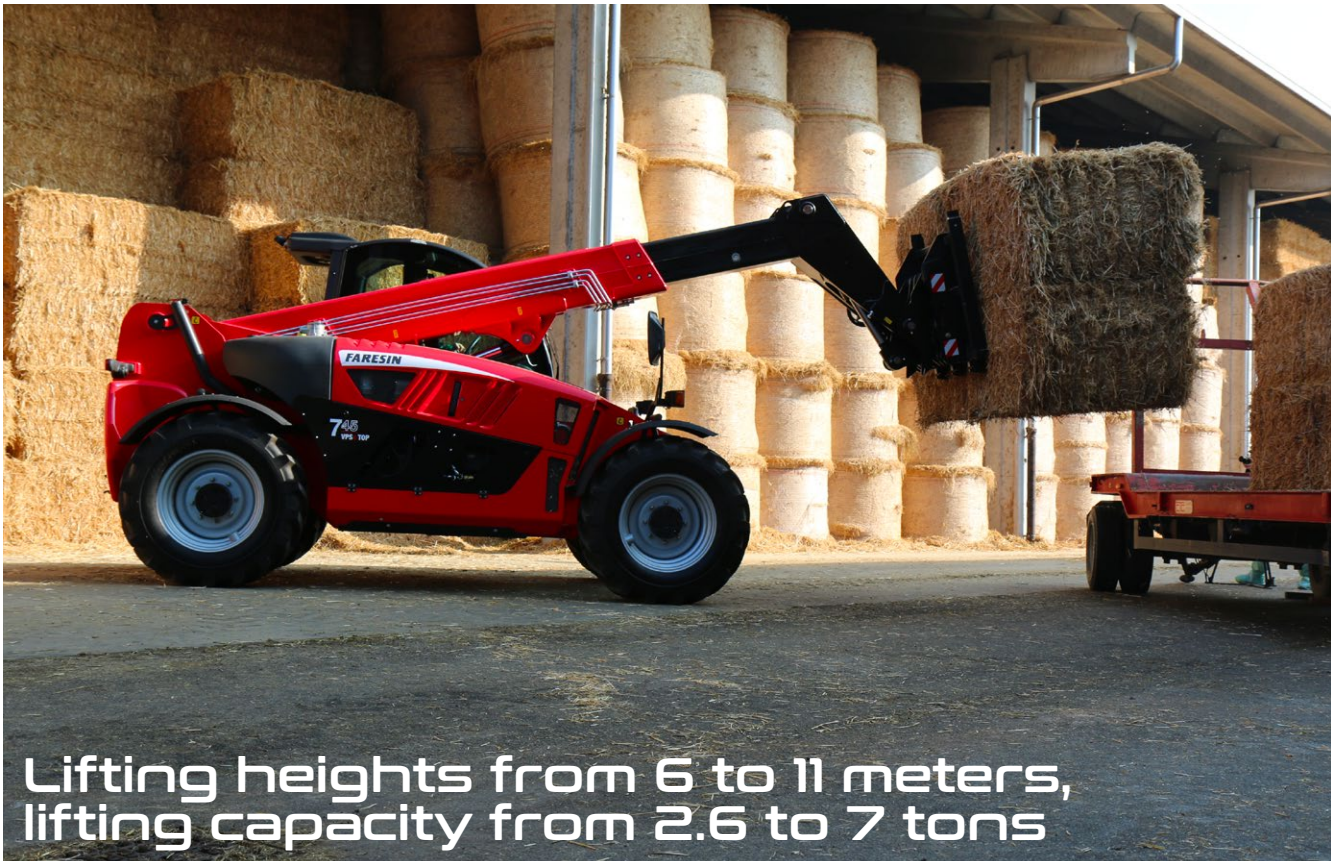

The telescopic boom is made of **Domex S420 steel** it is hinged in the chassis at a lowered position: this assures maximum visibility during loading operations and a better weight distribution.

- Internal hydraulic pipes
- Durability even during the most extreme work conditions
- Easy maintenance

**Reinforcement plates
for a long life span
even in the most
extreme working
conditions**



Small Range 6.26

CLASSIC 52

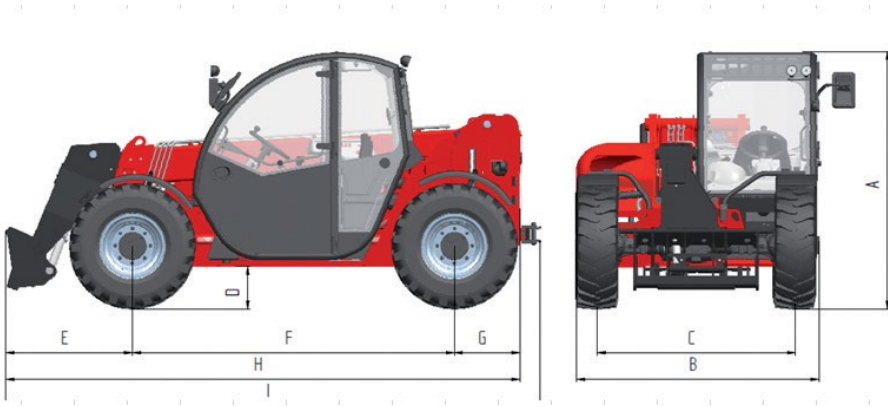

DIMENSIONS (mm)		6.26
A. Height		1935
B. Width		1890
C. Gauge		1550
D. Ground clearance		220
E. Front overhang		990
F. Pitch		2525
G. Rear overhang		520
H. Length without towing hook		4035
I. Length with towing hook		4198
L. Cabin width		960

Dimensions defined on model with wheels 12-16.5

Load diagram

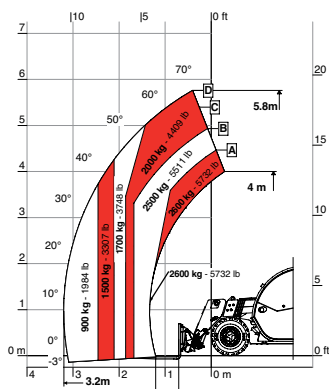

6.26

MODELS	6.26
WEIGHT	
Maximum total unladen weight (kg)	4700
SPECIFICATIONS	
Number of extracting sections	1
Maximum capacity (kg)	2600
Maximum lifting height (mt)	5,9
Maximum horizontal boom extension (mt)	3,2
Boom extension at max height (mt)	0,3
Forks swinging angle (°)	155
TANK CAPACITY	
Hydraulic oil tank (l)	70
Diesel oil tank (l)	80
CONNECTION FOR EQUIPMENT	
	FH

CONFIGURATION	CLASSIC 52
Engine (kW/hp)	Yanmar 51,7/69,3 IIIB/Tier4
Transmission	Hydrostatic
Service pump (l/min)	Gears 80 l/min@230 bar
Joystick	Mechanical electro-proportional
Traction power (kg)	3530
Display	Multi-function
Queen cab cabin	standard
Front and rear LED lights	optional
Manual 6-way diverter	optional
Rear hydraulic connection with dual electro proportional effect	optional
Rear trailer lights socket	optional
Engine water pre-heating	optional
Air conditioning	optional
Hydraulic trailer brakes	optional
Pneumatic trailer brakes	optional
Boom suspension	optional
Floating boom	optional
PEB manual 6-way diverter	optional
Wheels 12-16.5	standard
Wheels 12.5-18	optional
Creeper	optional
Front constant flow	optional
Bucket mode	standard
Quick release	optional

Compact Range 7.30C - 9.30C

CLASSIC 55 / CLASSIC 74 / HLS 55 / HLS 74 / VPS 100

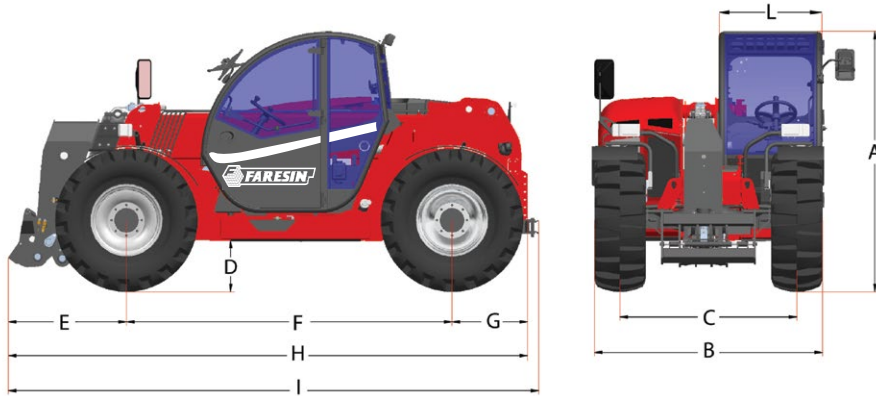

DIMENSIONS (mm)	7.30C	9.30C
A. Height	2230	2230
B. Width	2106	2106
C. Gauge	1640	1640
D. Ground clearance	320	320
E. Front overhang	1046	1046
F. Pitch	2950	2950
G. Rear overhang	684	684
H. Length without towing hook	4680	4680
I. Length with towing hook	4781	4781
L. Cabin width	960	960

Dimensions defined on CLASSIC model with wheels 405/70 - 20"

Load diagram

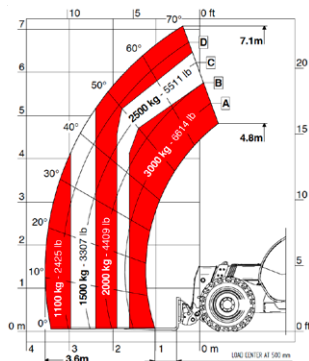

7.30C

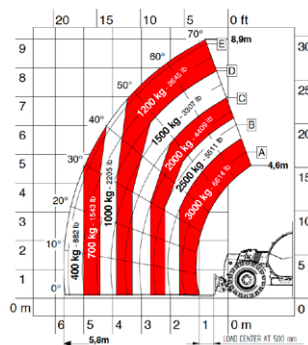

9.30C

MODELS	7.30C	9.30C
WEIGHT (kg)		
Classic 55	6290	6690
Classic 74	6400	6800
HLS 55	6450	6850
HLS 74	6600	7100
VPSe 100	6900	7300
SPECIFICATIONS		
Number of extracting sections	1	2
Maximum capacity (kg)	3000	3000
Maximum lifting height (mt)	7,1	8,8
Maximum horizontal boom extension (mt)	3,6	5,9
Boom extension at max height (mt)	0,3	0,8
Swinging angle of forks (°)	155	155
TANK CAPACITY		
Hydraulic oil tank (l)	150	150
Diesel oil tank (l)	120	120
CONNECTION FOR EQUIPMENT		
	FH	FH

CONFIGURATION	CLASSIC 55	CLASSIC 74	HLS 55	HLS 74	VPS 100
Engine (kW/hp)	Deutz Stage IIIB 55,4/75,3	Deutz Stage IV 74,4/101	Deutz Stage IIIB 55,4/75,3	Deutz Stage IV 74,4/101	Deutz Stage IV 100/136
Transmission	hydrostatic two mechanical gears	hydrostatic two mechanical gears	hydrostatic two mechanical gears	hydrostatic two mechanical gears	hydrostatic continuous variation
Service pump	gear pump 120 l/min @ 230bar	gear pump 120 l/min @ 230bar	LS piston pump 152 l/min @ 250bar	LS piston pump 152 l/min @ 250bar	LS piston pump 152 l/min @ 250bar
Traction power (kg)	4600	4600	4200	4200	6250
Front and rear LED lights	optional	optional	optional	optional	standard
Ecofast valve	optional	optional	standard	standard	standard
Creeper	optional	optional	standard	standard	standard
Floating boom	optional	optional	optional	optional	optional
Boom suspension	optional	optional	optional	optional	optional
Pneumatic/hydraulic trailer brakes	optional	optional	optional	optional	optional
Front constant flow	optional	optional	optional	optional	optional
Cabin	Queen Cab	Queen Cab	Queen Cab	Queen Cab	Queen Cab
Air conditioning	optional	optional	optional	optional	standard
Joystick	mechanical electro-proportional		hydraulic electro-proportional		
Manual 6-way diverter	optional	optional	optional	optional	standard
Rear trailer lights socket	optional	optional	optional	optional	standard
Quick release	optional	optional	optional	optional	standard
Tyres 405/70 - 20"	standard	standard	optional	optional	optional
Tyres 405/70 - 24"	optional	optional	standard	standard	standard
Tyres 445/70 - 24"R	optional	optional	optional	optional	optional
Bucket mode	standard	standard	standard	standard	standard

Middle Range 7.30E - 7.35 - 7.45 - 8.40 - 9.30 - 11.35

CLASSIC 55 / CLASSIC 74 / HLS 74 / VPSe 100

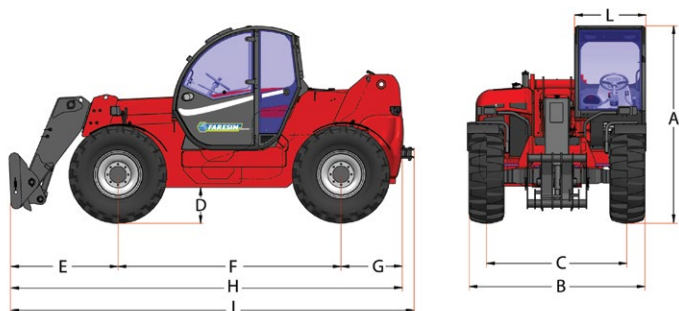

DIMENSIONS (mm)	7.30E	7.35	7.45	8.40	9.30	11.35
A. Height	2540	2540	2540	2540	2540	2540
B. Width	2368	2368	2368	2368	2368	2368
C. Gauge	1900	1900	1900	1900	1900	1900
D. Ground clearance	390	390	390	390	390	390
E. Front overhang	1008	1008	1008	1426	1997	1391
F. Pitch	2950	2950	2950	2950	2950	2950
G. Rear overhang	821	821	821	821	821	821
H. Length without towing hook	4771	4771	4771	5197	5768	5162
I. Length with towing hook	4849	4849	4849	5264	5838	5232
L. Cabin width	960	960	960	960	960	960

Dimensions defined on HLS model with wheels 405/70 - 24"

Load diagram

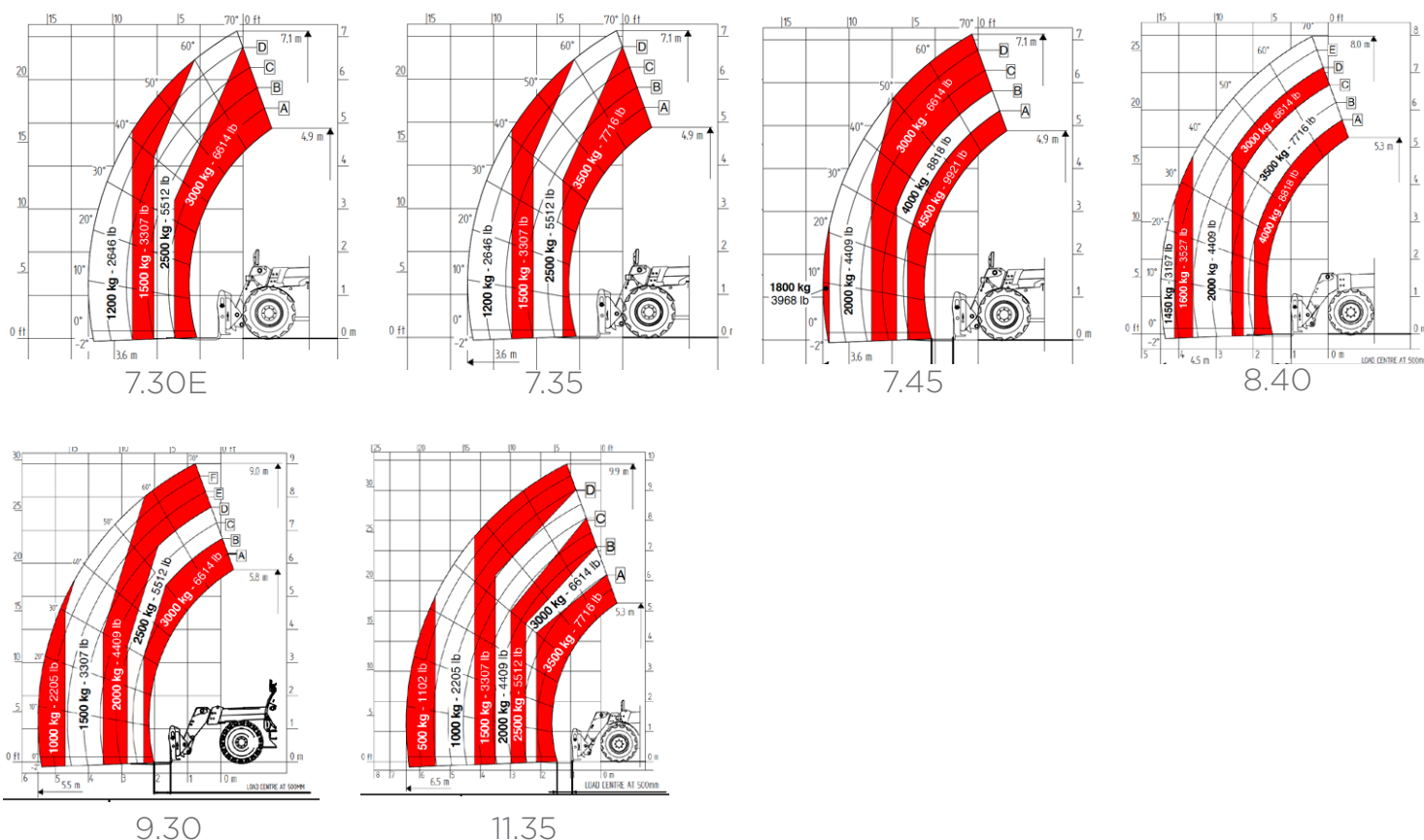

MODELS	7.30E	7.35	7.45	8.40	9.30	11.35
WEIGHT (kg)						
Classic 55	7490	7490	8090	8340	8440	8690
Classic 74	7500	7600	8200	8450	8550	8800
HLS 74	7700	7700	8300	8550	8650	8900
VPSe 100	7950	7950	8550	8800	8900	9150
SPECIFICATIONS						
Number of extracting sections	1	1	1	1	1	2
Maximum capacity (kg)	3000	3500	4500	4000	3000	3500
Maximum lifting height (mt)	7,1	7,1	7,1	8	9	9,9
Maximum horizontal boom extension (mt)	3,6	3,6	3,6	4,5	5,5	6,5
Boom extension at max height (mt)	0,2	0,2	0,2	0,4	0,8	1,2
Swinging angle of forks (°)	144	144	144	144	144	144
TANK CAPACITY						
Hydraulic oil tank (l)	150	150	150	150	150	150
Diesel oil tank (l)	120	120	120	120	120	120
CONNECTION FOR EQUIPMENT	EURO	FH	FH	FH	FH	FH

CONFIGURATION	CLASSIC 55	CLASSIC 74	HLS 74	VPSe 100
Engine (kW/hp)	Deutz Stage IIIB 55,4/75,3	Deutz Stage IV 74,4/101	Deutz Stage IV 74,4/101	Deutz Stage IV 100/136
Transmission	hydrostatic 30 km/h	hydrostatic 30 km/h	hydrostatic two mechanical gears 40 km/h	hydrostatic continuous variation 40 km/h
Service pump	gear pump 120 l/min@230 bar	gear pump 120 l/min@230 bar	LS piston pump 152 l/min@250 bar	LS piston pump 180 l/min@250 bar
Traction power (kg)	5200	5200	6000	10400
Front and rear LED lights	optional	optional	optional	standard
Ecofast valve	-	-	standard	standard
Creep	optional	optional	standard	standard
Floating boom	optional	optional	optional	optional
Boom suspension	optional	optional	optional	optional
Pneumatic/hydraulic trailer brakes	optional	optional	optional	optional
Front constant flow	optional	optional	optional	optional
Cabin	Queen Cab	Queen Cab	Queen Cab	Queen Cab
Air conditioning	optional	optional	optional	standard
Joystick	mechanical electro-proportional		hydraulic electro-proportional	
Manual 6-way diverter	optional	optional	optional	standard
Rear trailer lights socket	optional	optional	standard	standard
Electric preheating for engine water	optional	optional	optional	optional
Quick release	optional	optional	optional	standard
PEB	optional	optional	optional	optional
Tyres 405/70 - 20"	standard	standard	optional	optional
Tyres 405/70 - 24"	optional	optional	standard	standard
Tyres 445/70 - 24"R	optional	optional	optional	optional
Steering radius (mm)	4150 (405/70-20")	4150 (405/70-20")	4150 (405/70-24")	4200 (405/70-24")
Bucket mode	standard	standard	standard	standard

Heavy Duty Range 9.60 - 9.70 - 10.65

CLASSIC 74 / HLS 74 / VPSe 100

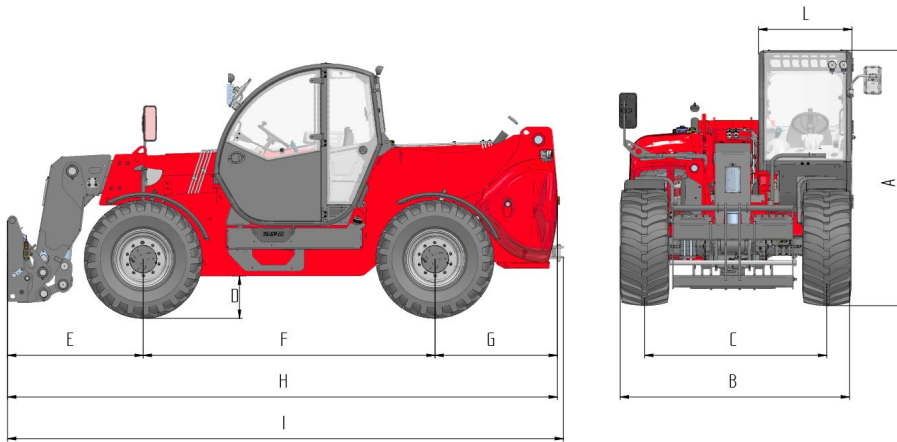

DIMENSIONS (mm)	9.60	9.70	10.65
A. Height	2550	2550	2550
B. Width	2334	2334	2334
C. Gauge	1840	1840	1840
D. Ground clearance	410	410	410
E. Front overhang	1373	1373	1673
F. Pitch	2950	2950	2950
G. Rear overhang	1265	1265	1265
H. Length without towing hook	5556	5556	5856
I. Length with towing hook	5628	5628	5556
L. Cabin width	960	960	960

Dimensions defined on model with wheels 445/65 R22,5

Load diagram

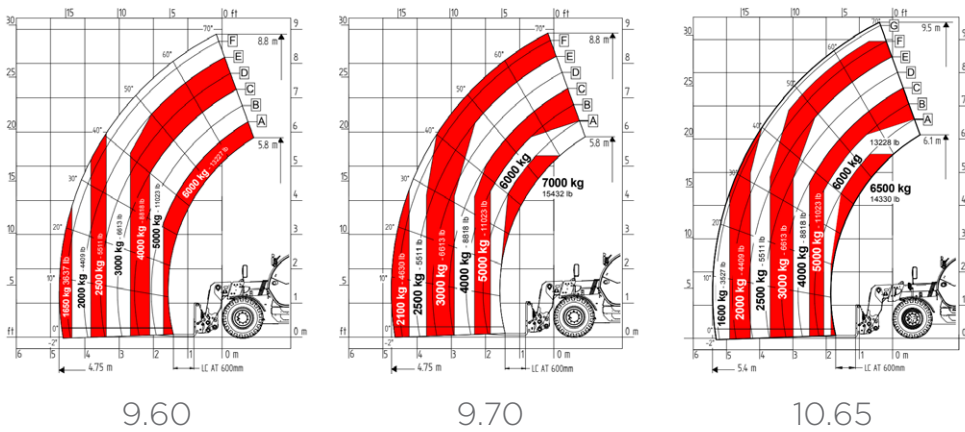

MODELS	9.60	9.70	10.65
WEIGHT (kg)			
Classic 74	10400	10700	11050
HLS 74	10600	10900	11200
VPSe 100	10750	11000	11250
SPECIFICATIONS			
Number of extracting sections	1	1	1
Maximum capacity (kg)	6000	7000	6500
Maximum lifting height (mt)	8,8	8,8	9,5
Maximum horizontal boom extension (mt)	4,75	4,75	5,4
Boom extension at max height (mt)	0,2	0,2	0,45
Swinging angle of forks (°)	149	149	149
TANK CAPACITY			
Hydraulic oil tank (l)	150	150	150
Diesel oil tank (l)	120	120	120
CONNECTION FOR EQUIPMENT			
	FH HEAVY DUTY	FH HEAVY DUTY	FH HEAVY DUTY

CONFIGURATIONS	CLASSIC 74	HLS 74	VPSe 100
Engine (kW/hp)	Deutz Stage IV 74,4/101	Deutz Stage IV 74,4/101	Deutz Stage IV 100/136
Transmission	hydrostatic two mechanical gears	hydrostatic two mechanical gears	hydrostatic continuous variation
Service pump	gear pump 120 l/min@230 bar	LS piston pump 152 l/min@ 250 bar	LS piston pump 180 l/min@ 250 bar
Traction power (kg)	8500	9000	10400
Joystick	mechanical electro-proportional	hydraulic electro-proportional	
Display	multi-function		
Queen Cab	standard	standard	standard
Front and rear LED lights	optional	optional	standard
Rear trailer lights socket	optional	standard	standard
Raising recycling valve	-	standard	standard
Electric preheating for engine water	optional	optional	optional
Air conditioning	optional	optional	standard
Hydraulic trailer brakes	optional	optional	optional
Pneumatic trailer brakes	optional	optional	optional
Boom suspension	optional	optional	optional
Floating boom	optional	optional	optional
Front constant flow	optional	optional	optional
Reversible fan	optional	optional	optional
Tyres 445/65-R - 22,5"	standard	standard	standard
Version 40 km/h	standard	standard	standard
Bucket mode	standard	standard	standard
Quick release	optional	optional	standard



Accessories



Manure fork with claws

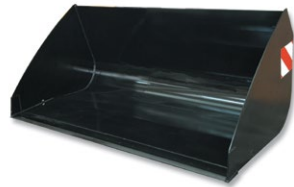

Light material bucket



Smooth bucket



Bucket without claws



Gripper for logs



Biting fork for dry round bales with second bale grip



Fork with 2 hinged needles



Fork with 3 hinged needles



Manure fork without claws



Silage shredding fork



Multi-function Bucket 4x1

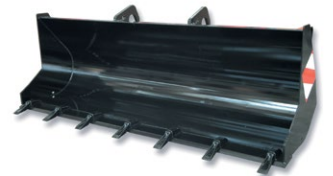

Toothed bucket



Claw for wrapped bales



Fork translator and positioner



Forks - L=1.2 m



Forks - L=2 m

Always by your side. Wherever needed.

After sale support - our added value.

Even the most advanced products in order to be successful must be supported by a quality after sales service. That's why we offer our customers **a quick and reliable support, 365 days a year, 24 hours a day, wherever they are.**

Original Faresin spare parts and accessories.

According to your needs and tailored for your Faresin machine, you will find everything you need. From **spare parts to high quality equipment and accessories.**

A wide range of original products which guarantees that your machine will **operate perfectly** and moreover, **for a long time to come.**



Spare parts catalogue always accessible and multilingual.

On our online spare parts catalogue, **SPM Spare Parts Management**, you will easily find all the information regarding our original spare parts for an optimal operation of your Faresin machine, in any language you wish.

You will also be able to create real-time offers, place orders and check their status, access document and folders.

Everything in order.

Our **WSP**, Warranty System Program, is quick and easy to use. This tool allows you to monitor all of your customers and their machinery.

Technology 4.0 applied to telescopic handlers and mixer wagons

Faresin Farmatics is the complete solution of Hardware, SIM, Web application and Server Data Management with which to remotely control the operation and performance of mixer wagons and telescopic handlers.

With the "Dealer Service" the Faresin Farmatics application ensures management of assistance, maintenance and warranties of the vehicle: through detailed reports, the customer is able to view the health status of their vehicle fleet, checking the consumption and productivity of each individual vehicle.

Faresin Farmatics enables monitoring of the alarms of both the engine and of the machine, detection of the machine position and definition of the area within which the machine must move (geofence) thus preventing the vehicle from moving into unsafe areas and also for the detection of possible intrusions.

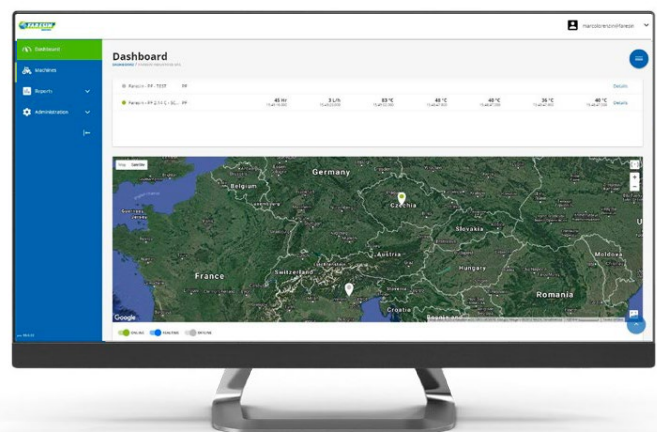

The Farmatics application can be customised to follow the product life cycle and to receive information relating to assistance problems, such as reporting on alarms, real-time display of the main machine parameters, hours of machine use and data for fault diagnosis.



"To reach my dreams and my ambitions, I still feel at the beginning ..."

Sante Faresin - Chairman

40+

Years of activity



World leadership



products exported

Craftsmanship soul and industrial heart. The strength of a global industrial productive group.

The company - founded in 1973 by the current Chairman, Sante Faresin - is a leader in the production and marketing of telescopic handlers for construction, industrial and agricultural use and of mixer wagons for the livestock sector.

Our greatest strength is to be able to blend a **strong industrial capacity** with the **tradition of a solid family guidance** and the **dynamism of an international group** with a global presence with branches in France, Germany and Poland and an extensive network of distributors and retailers.

Excellence, completely, Made in Italy.

From Research and Development to the final construction, our **industrial process** takes place **entirely in Italy** and to date, it includes all the production steps required to offer **high standards of quality and innovation.**

To confirm this industrial vocation, in the last few years a process of automation of the production areas and rationalisation of the internal handling systems has been started.

Green is better.

Lowering CO₂ emissions is not only an obligation but a heartfelt objective pursued each day.

An attention marking our entire production process. Each step assures an effective reduction of CO₂ emissions. All of this means lower consumptions and therefore also increased profitability for our customers.



Respect for the environment



Less CO₂ emissions



Less consumption



REV3 29/10/2018

**FARESIN INDUSTRIES SPA
HEADQUARTERS**
Via dell'Artigianato, 36
36042 Breganze (Vicenza) - Italy
Tel. + 39 0445 800300
faresin@faresin.com

FARESIN DEUTSCHLAND GMBH
Steinach B.R. - an der
Frankenhöhe 1
91605-Gallmersgarten - Germany
Tel. +49 9843 9802828
faresin-deutschland@gmx.de

FARESIN POLAND SP. Z O.O.
ul. Toruńska 3A, 87-640
Czernikowo - Polska
Office: + 48 54 234 06 72
Service: + 48 54 234 57 15
faresinpoland@faresin.com