



GAMA

NOVAYEN 1.2 / 1.4 / 1.6 t



Características	Fabricante		EUROYEN			
	1.1	Modelo SIN PLATAFORMA /CON PLATAFORMA	NOVAYEN 1230	NOVAYEN 1430	NOVAYEN 1630	
1.2	Tipo		Eléctrica			
1.3	Capacidad	Q (Kg)	1200	1400	1600	
1.4	Centro de carga	c(mm)	600	600	600	
1.5	Distancia entre ejes	y(mm)	1378	1378	1378	
Peso	2.1	Peso propio con batería	Kg	990	990	990
Ruedas	3.1	Tipo ruedas		PU	PU	PU
	3.2	Rueda Motriz	mm	250x80	250x80	250x80
	3.3	Rodillos delanteros	mm	85x70	85x70	85x70
	3.4	Ruedas estabilizadoras	mm	125x50	125x50	125x50
	3.5	Numero de ruedas delanteras / traseras		1x+2/4	1x+2/4	1x+2/4
	3.6	Vía delantera	b11(mm)	385	385	385
	3.7	Vía trasera	b10(mm)	620	620	620
	4.2	Elevación mínima	h13(mm)	90	90	90
	4.5	Largo total SIN / CON PLATAFORMA	L1(mm)	2013 / 2553	2013 / 2553	2030 / 2570
	4.6	Ancho total	b1(mm)	860	860	860
	4.7	Medida horquillas	s/e/l (mm)	65/185/1150	65/185/1150	65/185/1150
	4.8	Ancho exterior horquillas	b5 (mm)	570	570	570
4.9	Distancia al suelo, en medio de la distancia entre ejes	m2 (mm)	25	25	25	
4.10	Ancho pasillo, 1000x1200 palé cruzado	Ast(mm)	2220 / 2280	2220 / 2280	2220 / 2280	
4.11	Ancho pasillo, 800x1200 palé a lo largo	Ast(mm)	2270 / 2330	2270 / 2330	2270 / 2330	
4.12	Radio de giro externo	Wa(mm)	1570 /1630	1570 /1630	1570 /1630	
Ejecución	5.1	Velocidad tracción, con carga/sin carga	Km/h	5/5	5/5	5/5
	5.2	Velocidad elevación, con carga/sin carga	mm/s	110/160	110/160	110/160
	5.3	Velocidad descenso, con carga/sin carga	mm/s	170/180	170/180	170/180
	5.4	Gradabilidad máx., con carga/sin carga	%	6/10	6/10	6/10
Motores	6.1	Motor tracción	kW	1.5	1.5	1.5
	6.2	Motor elevación	kW	2.5	2.5	2.5
	6.3	Voltaje Batería	V/Ah	24/210	24/280	24/280
Otros	8.1	Tipo controlador		AC	AC	AC
		Fabricante		CURTIS	CURTIS	CURTIS

Nota: Con mástil triplex el largo del apilador es de +70mm

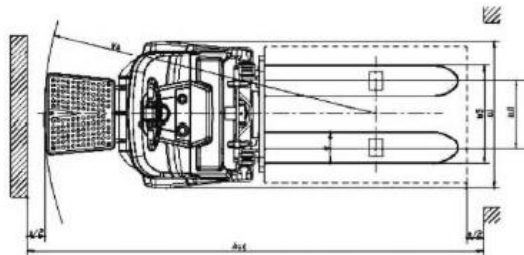
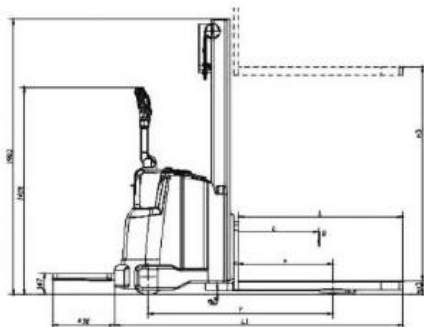

1.2t/1.4t/1.6t Mástil duplex (1 cilindro central)

Elevación h_3	Elevación máxima ($h_3 + h_{13}$)	Replegado h_1	Desplegado h_4	Elevación libre	Capacidad (centro de carga 600mm)		
					1.2t	1.4t	1.6t
mm	mm	mm	mm	mm	kg	kg	kg
2000	2090	1553	2553	90	1200	1400	1600
2500	2590	1803	3053	90	1200	1400	1600
2700	2790	1900	3253	90	1200	1400	1450
3000	3090	2053	3553	90	1200	1250	1300
3300	3390	2203	3853	90	1100	1100	1150
3500	3590	2388	4138	90	950	950	1000
3600	3690	2438	4238	90	950	950	1000

1.2t/1.4t/1.6t Mástil duplex (2 cilindros laterales)

Elevación h_3	Elevación máxima ($h_3 + h_{13}$)	Replegado h_1	Desplegado h_4	Elevación libre	Capacidad (centro de carga 600mm)		
					1.2t	1.4t	1.6t
mm	mm	mm	mm	mm	kg	kg	kg
2000	2090	1542	2542	90	1200	1400	1600
2500	2590	1792	3042	90	1200	1400	1600
2700	2790	1892	3142	90	1200	1400	1450
3000	3090	2042	3542	90	1200	1250	1300
3300	3390	2192	3842	90	1100	1100	1150
3500	3590	2292	4042	90	950	950	1000
3600	3690	2342	4142	90	950	950	1000
3800	3890	2442	4342	90	850	850	9000
4000	4090	2642	4642	90	750	750	800
4300	4390	2792	4942	90	600	600	650
4500	4590	2892	5142	90	500	500	500

1.2t/1.4t/1.6t Mástil triplex

Elevación h_3	Elevación máxima ($h_3 + h_{13}$)	Replegado h_1	Desplegado h_4	Elevación libre	Capacidad (centro de carga 600mm)		
					1.2t	1.4t	1.6t
mm	mm	mm	mm	mm	kg	kg	kg
3500	3590	1844	4214	1220	950	950	1000
3700	3790	1909	4409	1290	850	850	900
4000	4090	2009	4709	1390	750	750	800
4300	4390	2109	5009	1490	600	600	650
4500	4590	2159	5159	1590	500	500	550

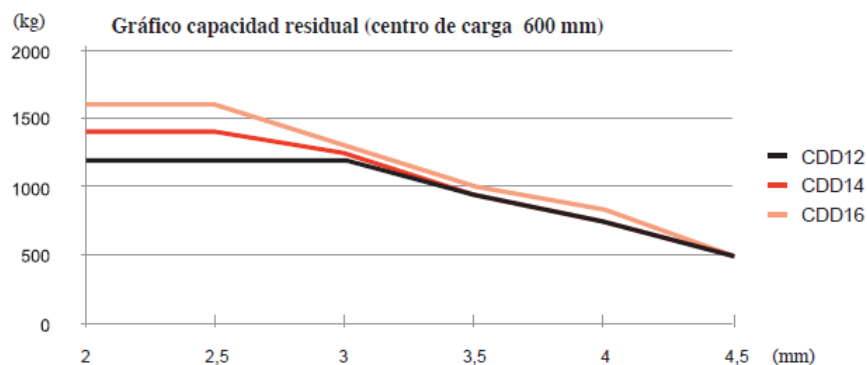

Los materiales y características están sujetos a modificaciones sin previo aviso. Datos validos salvo error de imprenta